

A New Generation in the Family of Packages for Transportation

Jean-Luc MONDANEL
Marketing General Manager

COGEMA LOGISTICS
BP 302
78054 Saint Quentin en Yvelines cedex
France
jlmondanel@cogemalogistics.com

A new generation of packages has been developed by COGEMA LOGISTICS to meet the various needs and requirements of the Laboratories and Research Reactors all over the world, following the 1996 Regulations.

A lot of packages existing till then had been used successfully for many years but could not comply to the changing regulatory context.

These new packages are adapted to various options, and are able to propose worldwide and long-term solutions for international transports of all kinds and sizes of materials from and to any site.

The **TN-UO₂** is a stainless package meeting IAEA 1996 ST-1 requirements, type A fissile, which can be used to ship several kinds of non irradiated materials, including reprocessed uranium.

Its multipurpose design and internal equipment enables to accommodate with many different contents, such as UO₂ powders, UO₂ pellets, as well as wastes and metallic uranium up to 5% enrichment.

The TN-UO₂ is rather a small package, user friendly, and easy to handle.

Its outer dimensions are : diameter 400 mm, and height 805 mm.

The cavity inner content dimensions are : diameter 260 mm, and height 580 mm.

The inner capacity is 23.7 liters.

Its maximum gross weight is 95 kg, and the maximum payload is 32.5 to 38 kg, depending on the enrichment.

The TN-UO₂ is used today on a daily basis in Europe, with more than 600 packages owned by French Companies : FBFC, COGEMA LOGISTICS ...

The package has also just received a validation by the Authorities for air shipments.

Due to increasing needs of transport of higher enrichments, an extension of the existing agreement has been applied for solid uranium enriched up to 20%.

As there are also further needs for high-enriched uranium, another extension is expected for 2003 for metallic uranium with enrichments up to 95%, including air shipments.

The TN-UO₂ is licensed in France, and validations are presently in progress in Belgium, the Netherlands, Germany, the United Kingdom, Sweden, the USA, and Canada.



The concept and the technology of the TN-UO₂ can be versatile, and can be adapted to fit some specific needs or requests : a derivative version of the package, called TNF-XI, has been designed and manufactured to meet Japanese market specific requirements.

There are presently 800 of these TNF-XI packages to be used in Japan.

The TNF-XI package is already licensed in France, and its agreement or validation are in progress in Japan and the USA.

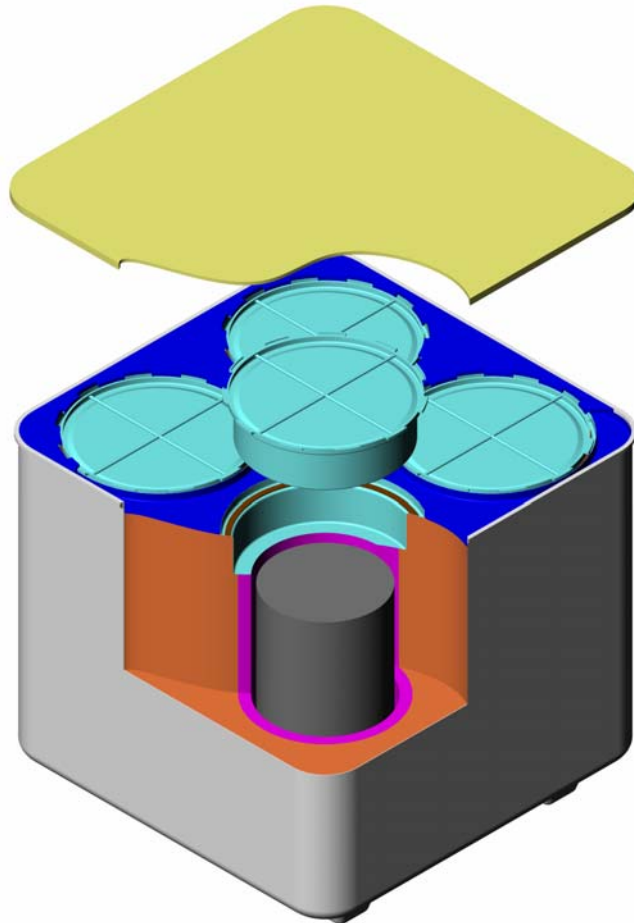

The TN-MTR presents a cylindrical cavity, in which today 7 different kinds of baskets are available to comply with the characteristics of the spent fuel to be shipped.

The body is covered with cooling fins, and a shock absorber is fitted on the top of the package, in transport configuration. Up to 76 assemblies can be shipped in one package.

The outer dimensions of the package are : 1,610 mm height, and 1,600 mm diameter without the shock absorber.

With the shock absorber, the height is 2,080 mm and the diameter 2,008 mm.

The inner cavity has a diameter of 960 mm and a height of 1,080 mm.

The 7 different baskets which can presently be used are :

- RHF : with 3 cylindrical holes for RHF fuel,
- MTR-4 : with 4 cylindrical holes for inner containers of diameter 336 mm maximum,
- MTR-44 : with 44 square holes for elements,
- MTR-52 : with 52 square holes for elements,
- MTR-52-S : with 52 sleeved square holes for elements, especially designed for the USA,
- MTR-61 : with 61 square holes for elements,
- MTR-68 : with 68 square holes for elements + 8 for smaller elements.

Other baskets can be created to suit new needs.

4 packages belong to French owners (COGEMA LOGISTICS, CEA) and are daily used, particularly in France and Belgium.

Several spot shipments are made in other parts of the world : European countries, the USA, Australia.

The TN-MTR concept enables either dry or easy wet loading and unloading on the sites. A transfer system can be used in order to facilitate the operations.

The most recent international operations took place in July 2002, and the wet loading of the fuel took only one hour at Risö, Denmark. The delivery at Savannah River was completed to the great satisfaction of the US DOE.

A renewed agreement has just been obtained in France and Belgium, and is in progress in Germany, Denmark, Australia and the USA.

TN-MTR CASK

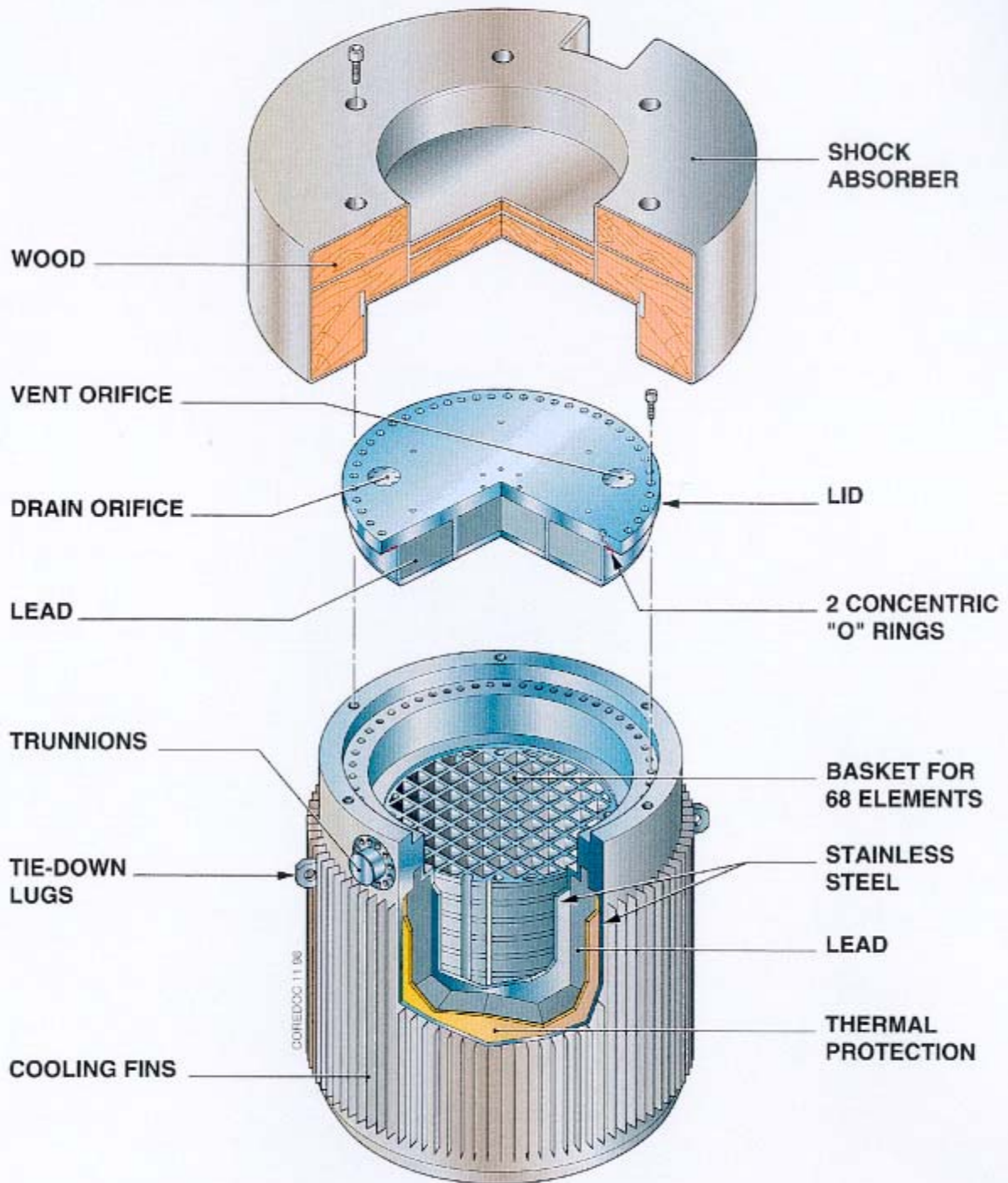

The **TN-106** is a brand new B (U) F package, meeting AIEA TS R1 regulations, and used for transport of irradiated fuel rods and pins in replacement of the old TN-6 family :

- irradiated fuel rods and pins with uranium oxide enriched at 10% maximum,
- irradiated fuel rods and pins with plutonium oxide or MOX with 12.5% Pu maximum,
- fuel rods and pins from Fast Breeder Reactors with 45% Pu maximum,
- non fissile solid radioactive materials,
- fuel elements with solid metallic uranium mixed to other metals (MTR, Triga, UNGG).

It enables both dry or wet loading and unloading, either in vertical or horizontal position, in order to meet the needs or requirements of Research Reactors or Laboratories, worldwide.

There is something exclusive, which makes the TN-106 a very original package : its design is based on a modular concept, allowing manufacturing of a series of packages with various useful cavity length from 1,000 to 3,200 mm, in accordance with the Research Reactor or Laboratory interface, needs or requirements.

A variety of internal arrangements may be designed for the TN-106 packaging, such as baskets, racks, capsules, etc. Specific internal arrangements can permit an increase of allowable fissile mass.

The TN-106 has received a 5 years agreement from French Authorities, for shipments by road, rail and sea. It is the first time that a license authorises variable length of cavity.

Validations of this agreement are presently under way in the US and in Europe in Denmark, Sweden, Switzerland, and soon in Germany.

For transport purpose, the TN-106 is tied-down by its 4 trunnions on a transport chassis, which can be loaded into an ISO container. It could also be covered by a tarpaulin.

The associated equipments consist of the transport chassis, the handling lifting beam, an IP2 box containing some tools, and the transport ISO container.

2 Handling lugs fixed onto the package enable also the handling of the package on its chassis.

2 shock absorbers are fixed on the package in transport configuration.

The outer dimensions of the package are :

Overall diameter : 1,458 mm with the shock absorbers,

958 mm including the trunnions, without the shock absorber,

820 mm excluding the trunnions, without the shock absorbers.

The overall length is 1,778 to 3,978 mm without the shock absorbers, and 2,424 to 4,614 mm with the shock absorbers.

As for the internal characteristics, the internal diameter is : 203 mm, and the useful cavity length : 1,000 to 3,200 mm.

The empty package weights from 5.8 to 12.4 tons without the shock absorbers.

The 2 shock absorbers weigh each 0.6 ton, and the overall loaded package with the 2 shock absorbers weigh from 7.2 up to 14.4 tons, depending on the length.

COGEMA LOGISTICS owns presently one TN-106, whose length is 2,200 mm. Another one is likely to be built in the near future, with a length of 2,400 mm.

The first test shipments have already occurred in October in France, at great satisfaction of the CEA units of Saclay, Grenoble and Cadarache, and now the operational shipments are going to start soon.

TN 106 CASK

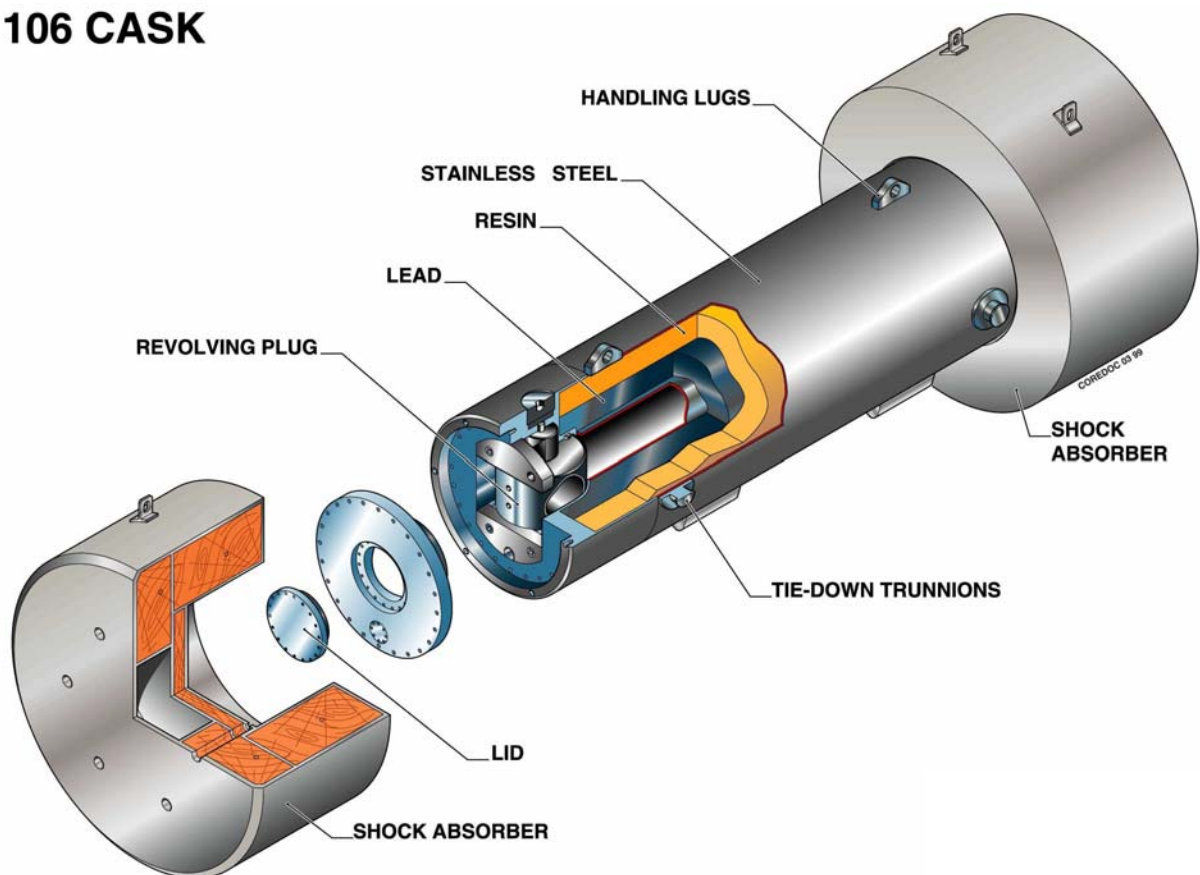

The **RD-26** is a stainless steel type B (U) package, which can be used for multipurpose shipments of various materials, such as :

- alpha contaminated technological wastes put into 118 liters drums (maximum 100 kg),
- UO₂ powder, pellets, or part of fuel rods put into specific drums (maximum 70 kg),
- liquid wastes, organic effluents and aqueous solutions in plastic bottles (maximum 150 kg).

The package concept presents one single containment barrier on the lid and orifice plug. A venting system can be proposed as an option.

The outer dimensions are : 1,145 mm height, and diameter 860 mm.

The inner dimensions of the cavity are : 780 mm height, and diameter 513 mm.

The mass of the empty package is 460 kg.

The filled package can weigh up to 530 to 610 kg maximum, depending on the contents.

The RD-26 can be handled on any site with classical means, such as forklifts, cranes and slings. Up to 12 packages can be loaded into a 20' ISO container using a specific rack.

Today, 72 packages are in operation, and more than 30 shipments are performed every year.



The **TN-CIEL** is an innovative concept of mobile tank vehicle type IP2, intended for road transportation of waste radioactive and potentially corrosive liquids :

- liquid effluents,
- concentrates of boric acid (H_3BO_3) with soda ($NaOH$) and phosphate,
- $CO60$ nuclides.

The tank is licensed LSA-II with respect to the IAEA recommendations, and, in Europe, with respect to the ADR road transport regulations for class 7 (radioactive materials), but also for the class 8 (corrosive materials).

The particularity of the liquid wastes is that it crystallises at ambient temperatures.

Therefore it must be transported at a minimum of $60^{\circ}C$. The TN-CIEL tank makes it possible by heating the cavity of the tank at a temperature regulated between 60 and $70^{\circ}C$ by electrical resistance. Moreover the TN-CIEL tank is equipped with an agitator in order to preclude precipitation in some colder zones.

A pump/compressor that can be connected to one of the three manholes allows loading and unloading of the radioactive liquids in the tank from and to any container.

The maximum allowable tank volume is 5 m^3 of low specific activity liquids.

The TN-CIEL mobile tank is now used on a daily basis for transports operations between the 18 EDF NPP to the French incineration facility CENTRACO Marcoule.

The total mass of the vehicle, under 40 tons, enables transport on any type of European road.

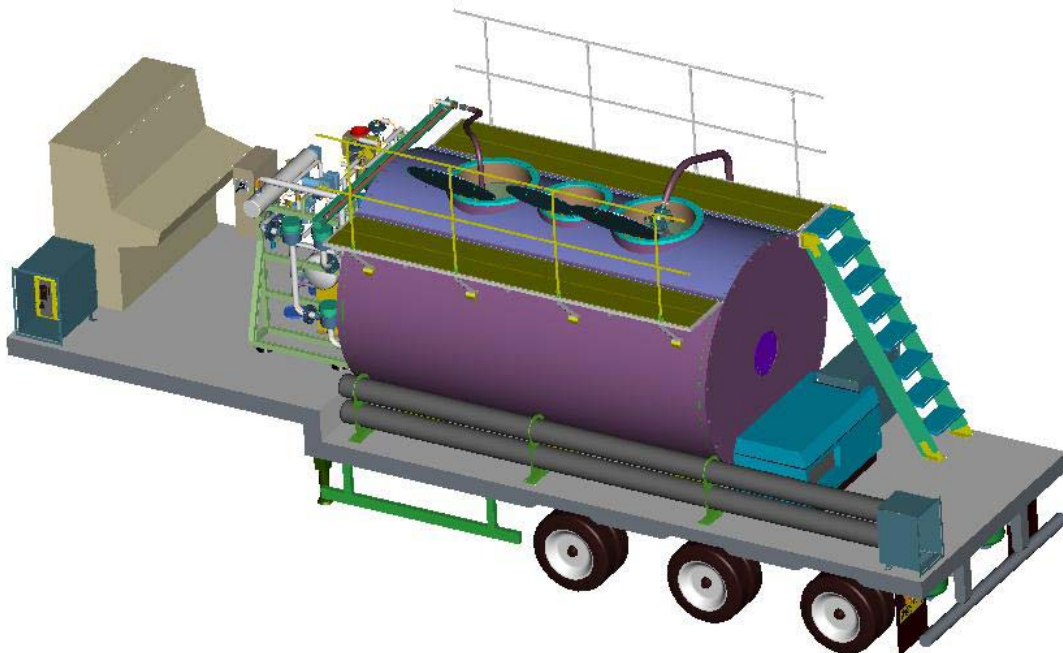

Conclusion :

There are also several other projects adapted to the specific needs of several international customers. All this new range of packages meets the latest requirements of the regulations or IAEA recommendations. Far more than the former generation, this new family enables multipurpose shipments, of a multiplicity of materials, adapted to a maximum of international sites, avoiding many problems of agreements and validations of specific contents.

